

# INSTALLATION INSTRUCTIONS FOR INSTALLING A TEA DISPENSER REPLACEMENT KIT IN A NATIONAL VENDORS®, CROWN SEVENTY TWO®, SERIES OR GOLDEN FURNITURE LINE HBM-614 AND HBM-618 HOT BEVERAGE MERCHANDISER

These instructions cover the procedure for installing a Tea Dispenser Replacement Kit in a Crown Seventy Two, Series or Golden Furniture Line HBM-614 and HBM-618 Hot Beverage Merchandiser.

Read these instructions carefully and thoroughly before installing the Kit. Retain these instructions for part number and installation information.

These instructions apply to two Kits. Kit, Part Number 613-7151 applies ONLY to the HBM-614 Merchandiser and contains the following parts:

Part Number	Description	Quantity
613-7144	Tea Dispenser Harness	1
613-7148	Tea Dispenser Assembly	1
9900-163	No.10-32 x 5/8 RHS S/T Screw	2
618-7001	Tea Mixing Bowl	1
112-7057	Knurled Head Screw	2
618-7002	Tea Mixing Bowl Vent	1
613-7001	Tea Dispenser Elbow	1
613-7137	Tea Water Valve to Tea Mixing Bowl Tube	1
613-7138	Tea Mixing Bowl to Mixing Bowl Tube	1
613-7161	Mixing Bowl Exhaust Hose	1
613-7173	Tea Exhaust Hose	1
610-7231	Vinyl Cap	2
613-7146	Tea Canister Assembly	1
613-7152	Installation Instructions	1
	* * *	

Kit, Part Number 618-7023, applies ONLY to the HBM-618 Merchandiser and contains the following parts:

613-7144	Tea Dispenser Harness	1
613-7148	Tea Dispenser Assembly	1
9900-204	No.8-32 x 5/8 RHS S/T Screw	2
618-7001	Tea Mixing Bowl	1
112-7057	Knurled Head Screw	2
618-7002	Tea Mixing Bowl Vent	1
613-7001	Tea Dispenser Elbow	1
618-7019	Tea Water Valve to Tea Mixing Bowl Tube	1
618-7020	Tea Mixing Bowl to Mixing Bowl Tube	1
618-7025	Tea Exhaust Hose	1
610-7231	Vinyl Cap	2
613-7146	Tea Canister Assembly	1
613-7152	Installation Instructions	1
	* * *	

## SPECIAL TOOLS REQUIRED (HBM-618 only)

Drill  
1/64 dia. Drill Bit

## TO INSTALL THE KIT

### A. PARTS REMOVAL

1. Unlock and open the Cabinet Door.
2. Move the Main Switch in the Merchandiser to the OFF position.
3. Remove the Tea Dispenser Exhaust Hose from the Merchandiser. See Figure 1 for HBM-614 Merchandisers and Figure 1A for HBM-618 Merchandisers.

#### NOTE

*Step 4 applies only to the HBM-614 Merchandiser.*

4. Remove the Mixing Bowl Exhaust Hose from the Merchandiser. See Figure 1.
5. Remove the Tea Dispenser to Mixing Bowl Tube from the Merchandiser. See Figure 1 or Figure 1A.

#### NOTE

*Step 6 applies only to the HBM-614 Merchandiser.*

6. Remove the Tea Dispenser Elbow (if equipped) from the bottom of the Tea Dispenser. See Figure 1.
7. Remove two Sidewall Thumb Screws and the Water Valve Cover Assembly from the Merchandiser. See Figure 1 or Figure 1A.
8. Remove the Tea Water Valve to Mixing Funnel Tube from the Merchandiser. See Figure 1 or Figure 1A.
9. Remove the Left Splash Panel Assembly from the Merchandiser. See Figure 2.
10. Disconnect the Tea Dispenser Harness from the Dry Ingredients Harness. See Figure 2.
11. Remove three No.10-32 x 5/8 Round Head Self Tapping Screws and the Tea Dispenser Assembly and Tea Jar from the Merchandiser. See Figure 1 or Figure 1A.

#### NOTE

*Step 12 applies only to an HBM-614 Merchandiser.*

Printed in U.S.A.

A Division of UMC Industries, Inc.

Copyright © 1975 by National Vendors

613-7152  
Rev. A

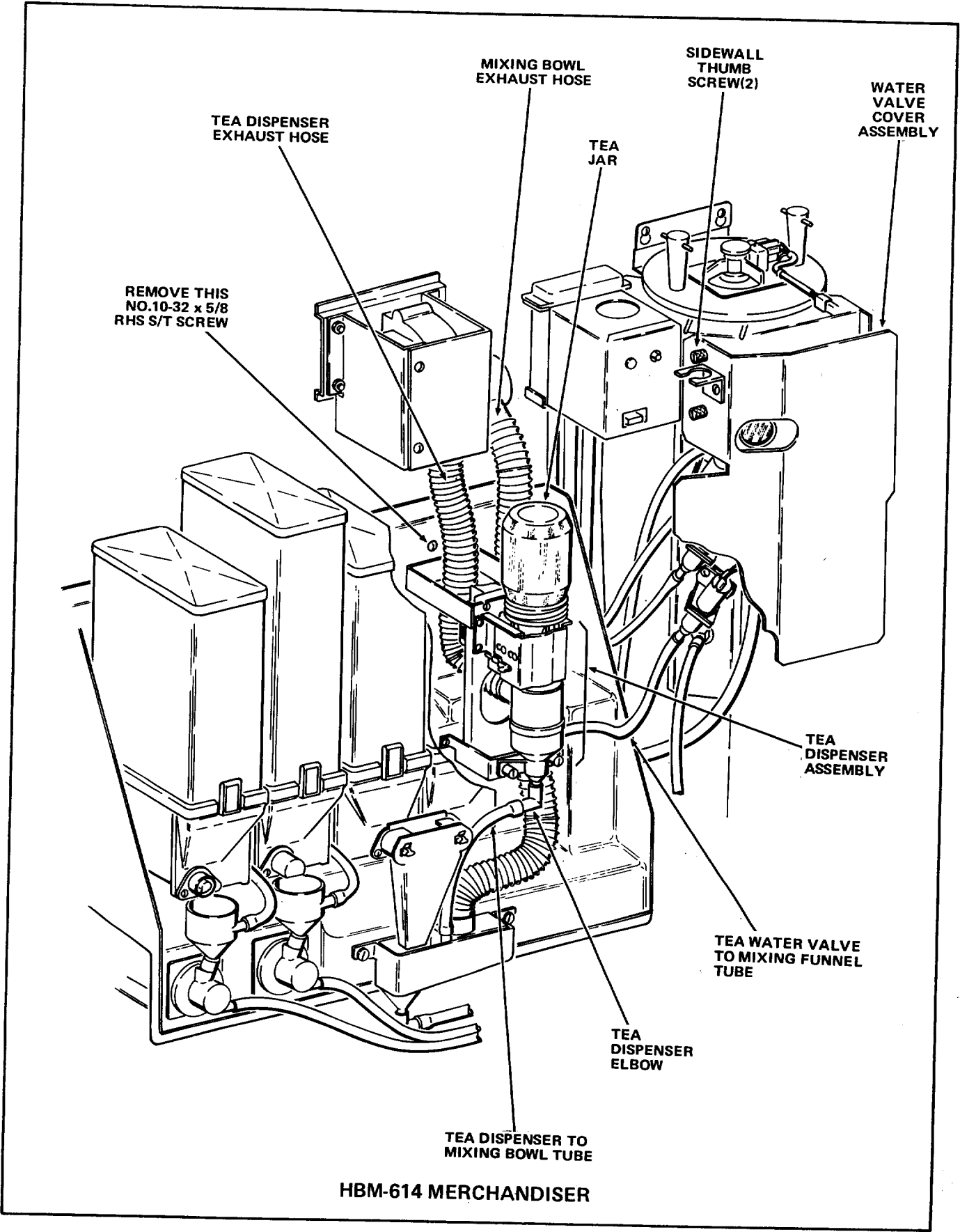

FIGURE 1

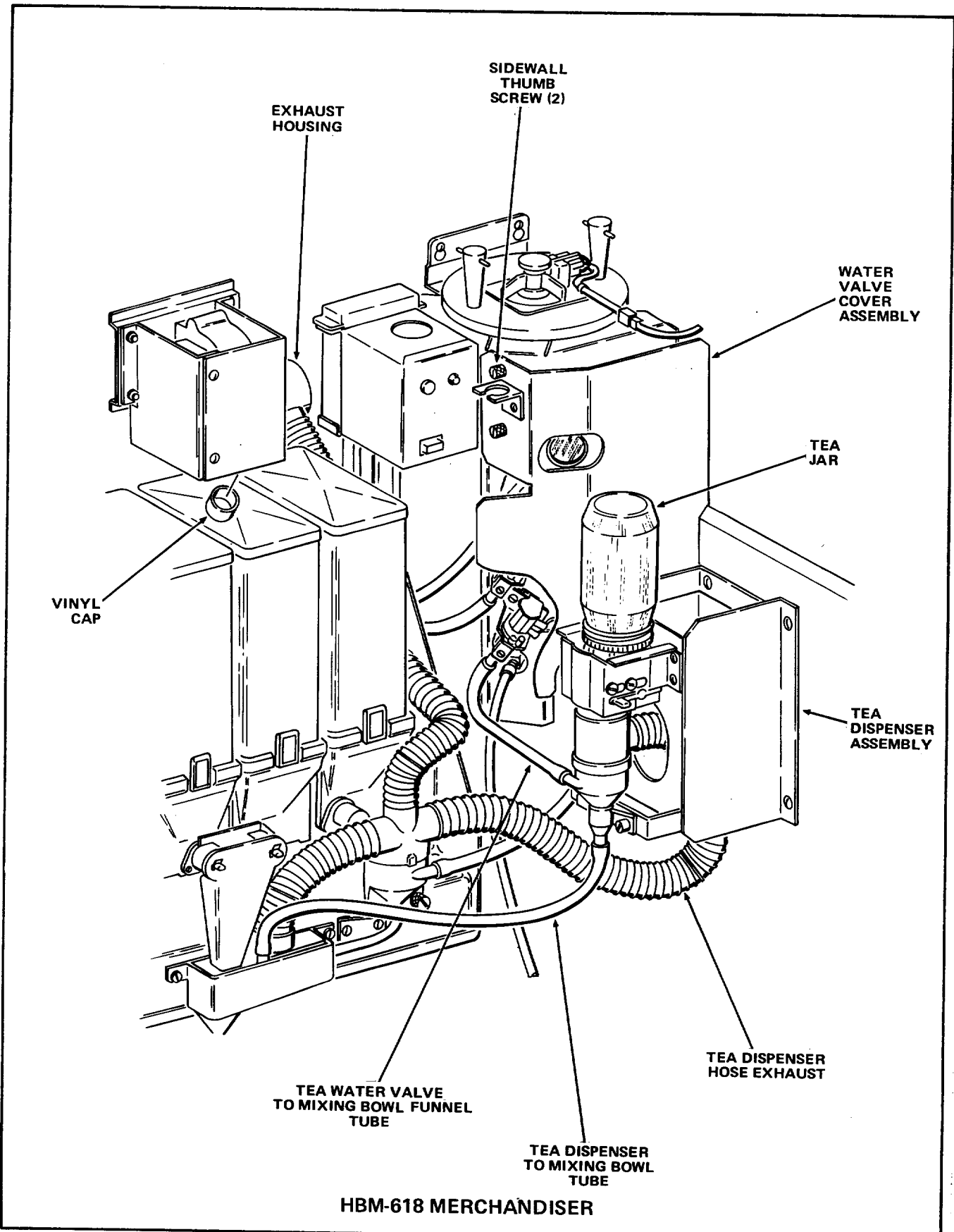

FIGURE 1A

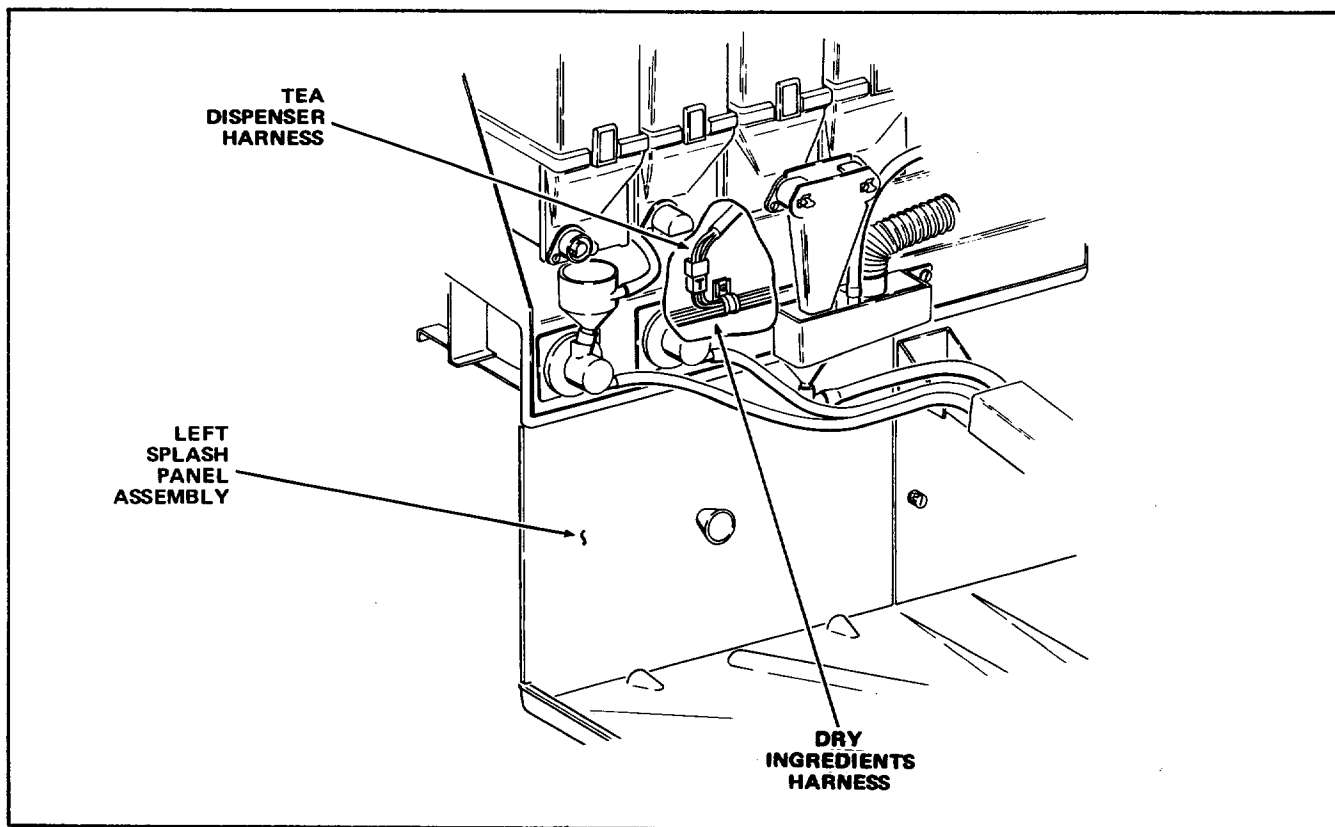

FIGURE 2

12. Remove a No.10-32 x 5/8 Round Head Self Tapping Screw from the upper part of the Dry Ingredients Shelf which was behind the Tea Dispenser Assembly. See Figure 1.

**NOTE**

*Step 13 applies only to an HBM-618 Merchandiser.*

13. Remove and retain the Vinyl Cap from the Exhaust Housing in the Merchandiser. See Figure 1A.

**B. INSTALLATION OF THE KIT**

**NOTE**

*Step 1 applies only to the HBM-618 Merchandiser.*

1. Using page 8 as a template, align the two top holes of the template with the two existing mounting holes on the Right Sidewall; then drill two 9/64 inch diameter holes where indicated. See Figure 3A.
2. Connect the Tea Dispenser Harness, Part Number 613-7144, included in the Kit, to the receptacle marked "T" on the Dry Ingredients Harness. See

Figure 2. On HBM-614 Merchandisers, run the other end of the Tea Dispenser Harness through the hole in the Dry Ingredients Shelf as shown in Figure 3. On HBM-618 Merchandisers, run the other end of the Tea Dispenser Harness around the Dry Ingredients Shelf as shown in Figure 3A.

3. Install the Left Splash Panel Assembly in the Merchandiser. See Figure 2.
4. Install the Tea Dispenser Assembly, Part Number 613-7148, included in the Kit, in the Merchandiser and attach with two No.10-32 x 5/8 Round Head Self Tapping Screws, Part Number 9900-163, included in Kit 613-7151 or two No.8-32 x 5/8 Round Head Self Tapping Screws, Part Number 9900-204, included in Kit 618-7023. See Figure 3 for HBM-614 Merchandisers or Figure 3A for HBM-618 Merchandisers.
5. Connect the free end of the Tea Dispenser Harness to the receptacle on the Tea Dispenser Assembly. See Figure 3 or Figure 3A.
6. Attach the Tea Mixing Bowl, Part number 618-7001, included in the Kit, to the Tea Dispenser Assembly using two Knurled Head Screws, Part Number 112-7057, included in the Kit. See Figure 3 or Figure 3A.

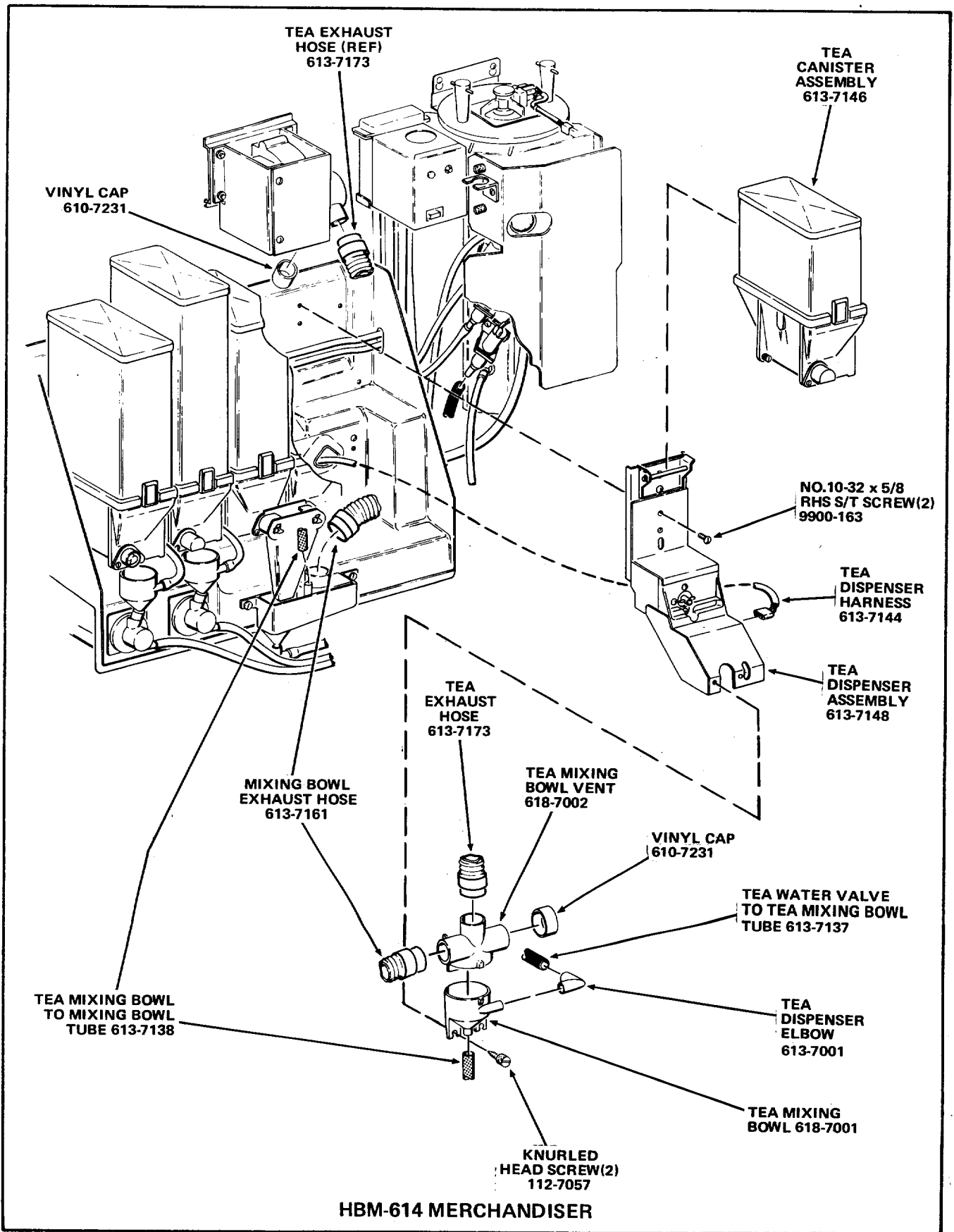

FIGURE 3

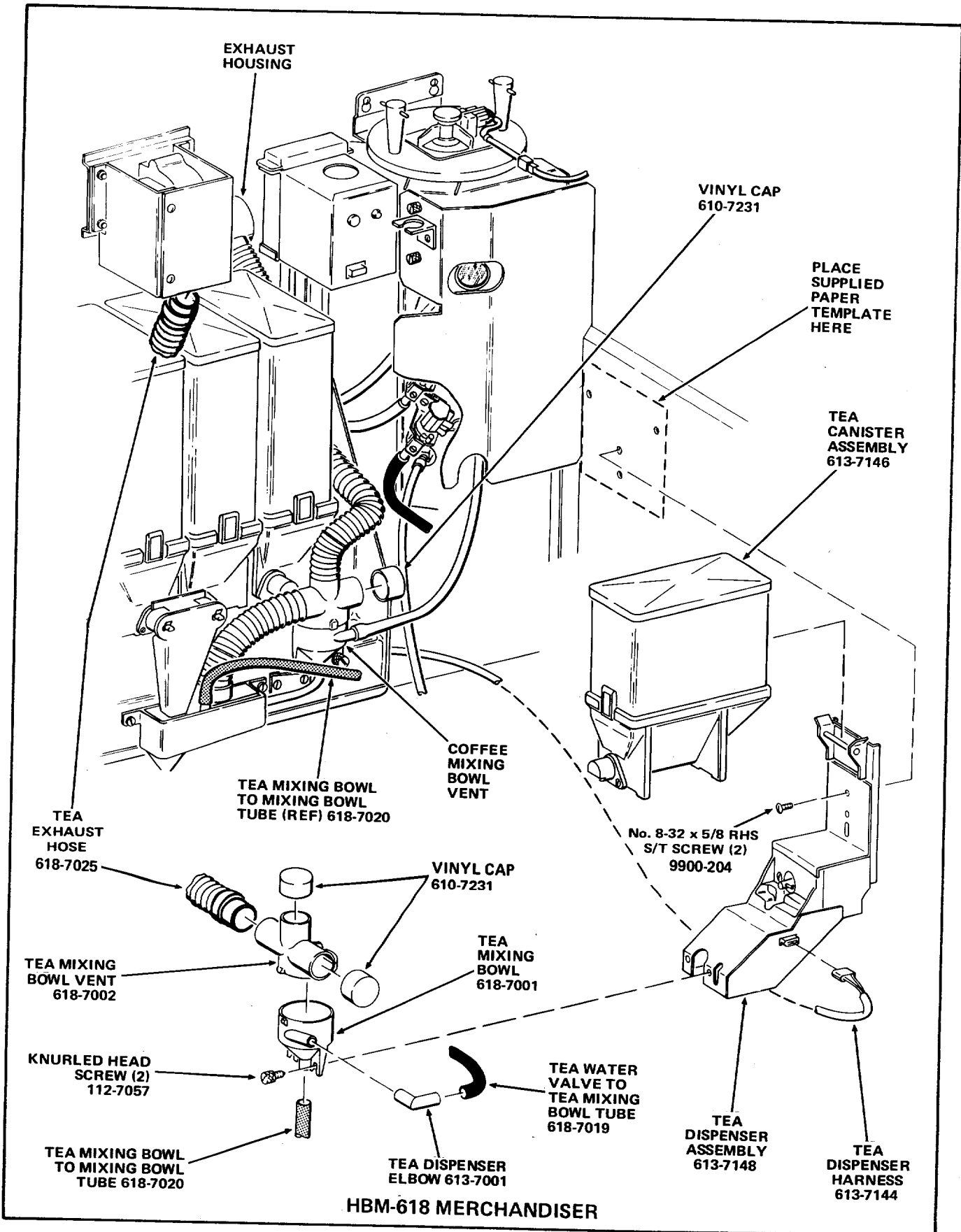

FIGURE 3A

7. Fit the Tea Mixing Bowl Vent, Part Number 618-7002, included in the Kit, on top of the Tea Mixing Bowl. See Figure 3 or Figure 3A.
8. Install the Tea Dispenser Elbow, Part Number 613-7001, included in the Kit, on the Tea Mixing Bowl. See Figure 3 or Figure 3A.

### NOTE

*Steps 9 through 13 apply only to the HBM-614 Merchandiser.*

9. Connect one end of the 10 inch Tea Water Valve to Tea Mixing Bowl Tube, Part Number 613-7137, included in the Kit, to the Tea Dispenser Elbow on the Tea Mixing Bowl and the other end of the Tube to the Tea Water Valve. See Figure 3.
10. Connect one end of the 8 3/4 inch Tea Mixing Bowl to Mixing Bowl Tube, Part Number 613-7138, included in the Kit, to the bottom of the Tea Mixing Bowl and the other end of the Tube to the Mixing Bowl. See Figure 3.
11. Connect one end of the shorter Mixing Bowl Exhaust Hose, Part Number 613-7161, included in the Kit, to the left side of the Tea Mixing Bowl Vent and the other end of the Mixing Bowl Exhaust Hose to the top of the Mixing Bowl. See Figure 3.
12. Connect one end of the longer Tea Exhaust Hose, Part Number 613-7173, included in the Kit, to the top of the Tea Mixing Bowl Vent and the other end of the Tea Exhaust Hose to the Exhaust Housing. See Figure 3.
13. Place the two Vinyl Caps, Part Number 610-7231, included in the Kit, over the openings in the Exhaust Housing and Tea Mixing Bowl Vent. See Figure 3.

### NOTE

*Steps 14 through 18 apply only to the HBM-618 Merchandiser.*

14. Connect one end of the 11 3/4 inch Tea Water Valve to Tea Mixing Bowl Tube, Part Number 618-7019, included in the Kit, to the Tea Dispenser Elbow on the Tea Mixing Bowl and the other end of the Tube to the Tea Water Valve. See Figure 3A.
15. Connect one end of the 12 1/2 inch Tea Mixing Bowl to Mixing Bowl Tube, Part Number 618-7020, included in the Kit, to the bottom of the Tea Mixing Bowl and the other end of the Tube to the Mixing Bowl. See Figure 3A.
16. Place the Vinyl Cap, removed in Step A-13, over the opening on the right side of the Coffee Mixing Bowl Vent. See Figure 3A.
17. Connect one end of the Tea Exhaust Hose, Part Number 618-7025, included in the Kit, to the left side of the Tea Mixing Bowl Vent and the end of the Tea Exhaust Hose to the Exhaust Housing. See Figure 3A.
18. Place the two Vinyl Caps, Part Number 610-7231, included in the Kit, over the openings on the Tea Mixing Bowl Vent. See Figure 3A.
19. Place the Tea Canister Assembly, Part Number 613-7146, included in the Kit, on the Tea Dispenser Assembly making sure the Canister Hanger on the rear of the Tea Canister Assembly hooks on the Canister Mounting Bracket Assembly and that the roll pin on the Tea Dispenser Motor fits in the Coupling on the Tea Auger Assembly. See Figure 3 or Figure 3A.
20. Remove the Lid from the Tea Canister Assembly and fill the Canister with Tea or De-Caffeinated Coffee. Place the Lid back on the Tea Canister Assembly.

### C. CHECKS AND ADJUSTMENTS

1. Follow the procedures in the Set-Up Instructions for testing and adjusting the Tea Powder Throw or De-Caffeinated Coffee Throw.
2. Close and lock the Cabinet Door.

R | L

EXISTING HOLES  
FOR MOUNTING  
OLD TEA DISPENSER  
ON HBM-618 MERCHANDISERS

